

RACAL INSTRUMENTS
1260-100/101
ADAPT-a-SWITCH
CARRIER MODULE

PUBLICATION NO. 980824-100

EADS North America Defense Test and Services, Inc.
4 Goodyear, Irvine, CA 92618
Tel: (800) 722-2528, (949) 859-8999; Fax: (949) 859-7139

info@eads-nadefense.com
sales@eads-nadefense.com
helpdesk@eads-nadefense.com
<http://www.eads-nadefense.com>



PUBLICATION DATE: July 26, 2004

Copyright 1998 by EADS North America Defense Test and Services, Inc. Printed in the United States of America. All rights reserved. This book or parts thereof may not be reproduced in any form without written permission of the publisher.

**THANK YOU FOR PURCHASING THIS
EADS NORTH AMERICA DEFENSE TEST AND SERVICES PRODUCT**

For this product, or any other EADS North America Defense Test and Services, Inc. product that incorporates software drivers, you may access our web site to verify and/or download the latest driver versions. The web address for driver downloads is:

<http://www.eads-nadefense.com/downloads>

If you have any questions about software driver downloads or our privacy policy, please contact us at

info@eads-nadefense.com

WARRANTY STATEMENT

All EADS North America Defense Test and Services, Inc. products are designed and manufactured to exacting standards and in full conformance to EADS ISO 9001:2000 processes.

This warranty does not apply to defects resulting from any modification(s) of any product or part without EADS North America Defense Test and Services, Inc. express written consent, or misuse of any product or part. The warranty also does not apply to fuses, software, non-rechargeable batteries, damage from battery leakage, or problems arising from normal wear, such as mechanical relay life, or failure to follow instructions.

This warranty is in lieu of all other warranties, expressed or implied, including any implied warranty of merchantability or fitness for a particular use. The remedies provided herein are buyer's sole and exclusive remedies.

For the specific terms of your standard warranty, or optional extended warranty or service agreement, contact your EADS North America Defense Test and Services, Inc. customer service advisor. Please have the following information available to facilitate service.

1. Product serial number
2. Product model number
3. Your company and contact information

You may contact your customer service advisor by:

E-Mail:	Helpdesk@eads-nadefense.com	
Telephone:	+1 800 722 3262	(USA)
Fax:	+1 949 859 7309	(USA)

RETURN of PRODUCT

Authorization is required from EADS North America Defense Test and Services, Inc. before you send us your product for service or calibration. Call or contact the Customer Support Department at 1-800-722-3262 or 1-949-859-8999 or via fax at 1-949-859-7139. We can be reached at: helpdesk@eads-nadefense.com.

PROPRIETARY NOTICE

This document and the technical data herein disclosed, are proprietary to EADS North America Defense Test and Services, Inc., and shall not, without express written permission of EADS North America Defense Test and Services, Inc., be used, in whole or in part to solicit quotations from a competitive source or used for manufacture by anyone other than EADS North America Defense Test and Services, Inc. The information herein has been developed at private expense, and may only be used for operation and maintenance reference purposes or for purposes of engineering evaluation and incorporation into technical specifications and other documents which specify procurement of products from EADS North America Defense Test and Services, Inc.

DISCLAIMER

Buyer acknowledges and agrees that it is responsible for the operation of the goods purchased and should ensure that they are used properly and in accordance with this handbook and any other instructions provided by Seller. EADS North America Defense Test and Services, Inc. products are not specifically designed, manufactured or intended to be used as parts, assemblies or components in planning, construction, maintenance or operation of a nuclear facility, or in life support or safety critical applications in which the failure of the EADS North America Defense Test and Services, Inc. product could create a situation where personal injury or death could occur. Should Buyer purchase EADS North America Defense Test and Services, Inc. product for such unintended application, Buyer shall indemnify and hold EADS North America Defense Test and Services, Inc., its officers, employees, subsidiaries, affiliates and distributors harmless against all claims arising out of a claim for personal injury or death associated with such unintended use.

FOR YOUR SAFETY

Before undertaking any troubleshooting, maintenance or exploratory procedure, read carefully the **WARNINGS** and **CAUTION** notices.



CAUTION
RISK OF ELECTRICAL SHOCK
DO NOT OPEN



This equipment contains voltage hazardous to human life and safety, and is capable of inflicting personal injury.



If this instrument is to be powered from the AC line (mains) through an autotransformer, ensure the common connector is connected to the neutral (earth pole) of the power supply.



Before operating the unit, ensure the conductor (green wire) is connected to the ground (earth) conductor of the power outlet. Do not use a two-conductor extension cord or a three-prong/two-prong adapter. This will defeat the protective feature of the third conductor in the power cord.



Maintenance and calibration procedures sometimes call for operation of the unit with power applied and protective covers removed. Read the procedures and heed warnings to avoid “live” circuit points.

Before operating this instrument:

1. Ensure the proper fuse is in place for the power source to operate.
2. Ensure all other devices connected to or in proximity to this instrument are properly grounded or connected to the protective third-wire earth ground.

If the instrument:

- fails to operate satisfactorily
- shows visible damage
- has been stored under unfavorable conditions
- has sustained stress

Do not operate until, performance is checked by qualified personnel.

Racal Instruments

EC Declaration of Conformity

We

Racal Instruments Inc.
4 Goodyear Street
Irvine, CA 92718

declare under sole responsibility that the

1260-100 Switch System Carrier
P/N 407655

conform to the following Product Specifications:

Safety: EN 61010-1

EMC: EN50081-1
CISPR 11:1990/EN 55011 (1991): Group 1 Class A
IEC 801-2:1991/EN 50082-1 (1992): 4 kV CD, 8 kV AD
IEC 801-3:1984/EN 50082-1 (1992): 3 V/m, 27-500 MHz
IEC 801-4:1988/EN 50082-1 (1992): 1 kV

Supplementary Information:

The above specifications are met when the product is installed in a Racal Instruments certified mainframe with faceplates installed over all unused slots, as applicable.

The product herewith complies with the requirements of the Low Voltage Directive 73/23/EEC and the EMC Directive 89/336/EEC.

Irvine, CA, November 12, 1998

Quality Manager

This page was left intentionally blank.

Racal Instruments

EC Declaration of Conformity

We

Racal Instruments Inc.
4 Goodyear Street
Irvine, CA 92718

declare under sole responsibility that the

1260-101 Single Slot Adapt-a-Switch, P/N 407956

conforms to the following Product Specifications:

Safety: EN61010-1:1993+A2:1995

EMC: EN61326:1997+A1:1998

Supplementary Information:

The above specifications are met when the product is installed in a Racal Instruments certified mainframe with faceplates installed over all unused slots, as applicable

The product herewith complies with the requirements of the Low Voltage Directive 73/23/EEC and the EMC Directive 89/336/EEC (modified by 93/68/EEC).

Irvine, CA, October 8, 2004

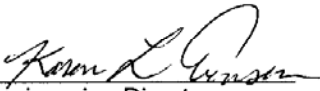
Engineering Director

This page was left intentionally blank.

Table Of Contents

Chapter 1	1-1
OVERVIEW.....	1-1
Items Shipped with 1260-100/101	1-1
Functional Description.....	1-2
Features	1-3
Compatibility with 1260-Series	1-3
Ease of Use	1-3
Maintainability	1-3
Dynamically-Configured Analog Bus	1-4
Chapter 2	2-1
GETTING STARTED	2-1
Unpacking and Inspection	2-1
Reshipment Instructions.....	2-1
Option-01T	2-2
Setting Configuration Switches	2-6
Local Bus Daisy-Chain Switches	2-6
Logical Address Switch (only if Option-01T installed).....	2-6
Module Address Switch.....	2-7
1260-100 Module Address	2-7
1260-101 Module Address	2-9
Inserting and Removing Plug-Ins	2-9
Installing the 1260-100/101 into a VXIbus Chassis.....	2-9

Making Connections to Plug-Ins (Pin-Outs)	2-10
Power-On Self-Test.....	2-10
Closing and Opening Relays.....	2-10
Chapter 3	3-1
USING THE 1260-100/101	3-1
Checking the Response of Plug-Ins	3-1
Closing and Opening Relays.....	3-1
Emergency Reset Function	3-1
Description.....	3-1
Interface.....	3-2
Normal State of External Switch	3-2
Scope of Reset Event	3-2
Sequence of Events	3-2
Chapter 4	4-1
MAINTENANCE.....	4-1
Performance Verification Procedure	4-1
Purpose	4-1
Equipment Required.....	4-1
Software Required.....	4-1
Procedure	4-1

Chapter 5	5-1
PRODUCT SUPPORT	5-1
Product Support	5-1
Warranty	5-1
Appendix A.....	A-1
1260 SPECIFICATIONS	A-1
General.....	A-1
Mechanical.....	A-1
Electrical	A-1
Power and Cooling	A-2
Environmental.....	A-2
EMC and Safety.....	A-2
Reliability	A-2
General.....	A-3
Mechanical.....	A-3
Electrical	A-3
Power and Cooling	A-4
Environmental.....	A-4
EMC and Safety.....	A-4
Reliability	A-4

Appendix B	B-1
1260-101 THEORY OF OPERATION.....	B-1
Mezzanine PCB Assembly	B-1
General.....	B-1
Power Filtering.....	B-1
Signal Connections.....	B-2
Power Distribution	B-2
Signals	B-2
Bridge PCB Assembly	B-3
Local Bus Signal Routing	B-3
Reset Circuit	B-3
Interrupt	B-4
Communications	B-4
Power Distribution	B-5
PLD Programming Connector	B-5
General	B-5
Power Filtering.....	B-5
Signal Connections.....	B-6
Power Distribution	B-6
Signals.....	B-6
Mezzanine PCB Assembly	B-7
Local Bus Signal Routing	B-7
Reset Circuit	B-7
Interrupt	B-8
Communications	B-8
PLD Programming Connector.....	B-9

Appendix C	C-1
TROUBLESHOOTING	C-1
Troubleshooting Table.....	C-1
Communications Troubleshooting	C-2

List Of Figures

Figure 1-1, The 1260-100	1-1
Figure 1-2, 1260-100 Adapt-a-Switch Carrier	1-2
Figure 1-3, Ease-of-Use Features	1-4
Figure 2-1, Installing the Option-01T in the 1260-100	2-5
Figure 2-2, Configuration Switches.....	2-6

Chapter 1

OVERVIEW

Items Shipped with 1260-100/101

The following items are shipped with each 1260-100/101 Adapt-a-Switch Carrier:

ITEM	PART NUMBER	QUANTITY
Lockout key, type A	456663-001	2
Lockout key, type C	456663-002	2
Blanking plate	407667	1/3
Instruction manual	980824-100	1

The following accessories may be ordered separately:

- Option-01T Switch Controller, Part Number 407531-001

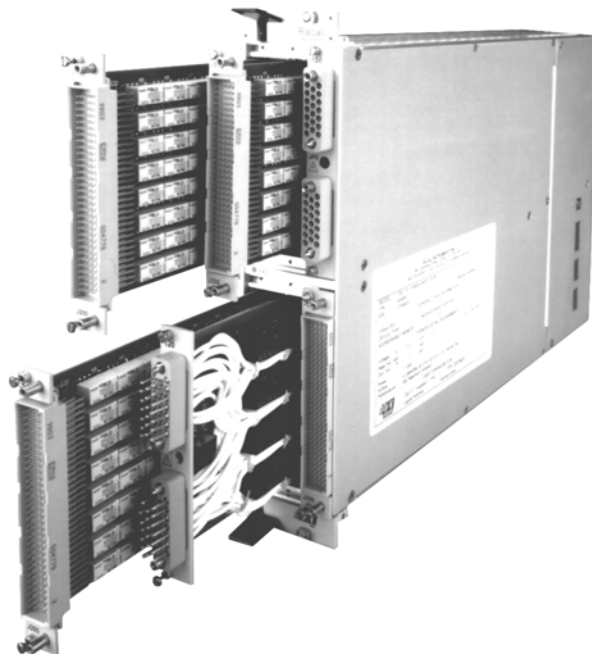

Figure 1-1, The 1260-100

Functional Description

The 1260-100 Adapt-a-Switch Carrier is a two-slot VXIbus module that may contain up to six Adapt-a-Switch plug-ins. You may leave some slots unoccupied for future expansion.

The 1260-101 Adapt-a-Switch Carrier is a single-slot VXIbus module that contains two Adapt-a-Switch plug-ins. **Figure 1-2** shows the 1260-100 with plug-ins.

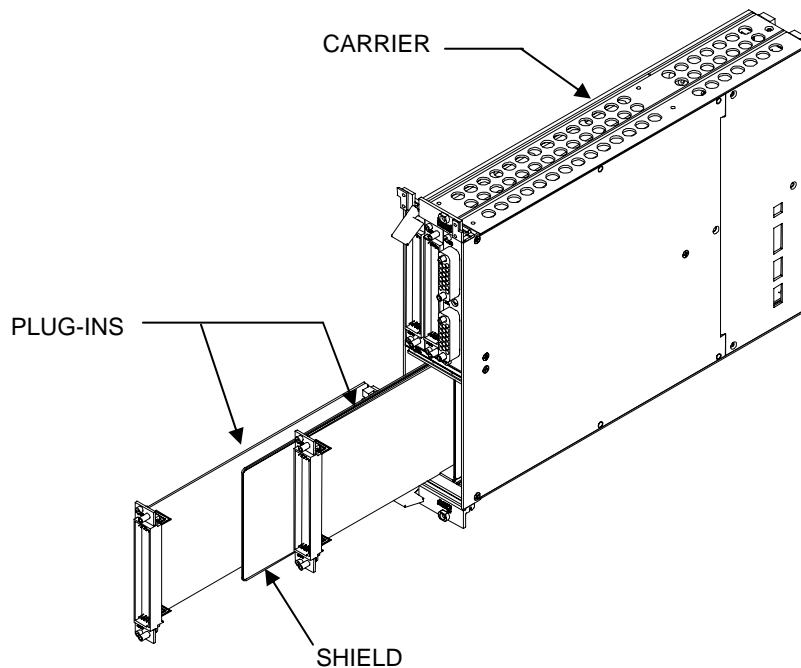

Figure 1-2, 1260-100 Adapt-a-Switch Carrier

Each plug-in has its own unique configuration of relays or digital testing capabilities, such as:

- Switch, for connecting individual pairs of inputs together.
- Multiplexer (mux), for connecting one input to any one of several outputs.
- Matrix. A matrix has two groups of channels: a row and a column. The matrix can connect any row channel to any column channel. The matrix may make multiple independent connections at the same time.
- RF switch, for switching radio-frequency signals via impedance-matched signal paths.
- Digital I/O, for a wide range of digital test applications.

Features

Compatibility with 1260-Series

The 1260-100 /101 Adapt-a-Switch Carrier uses the same Option-01T controller as conventional 1260-Series switch modules. A single Option-01T Switch Controller Module may control up to twelve switch modules or plug-ins. This may include a combination of 1260-Series and Adapt-a-Switch plug-ins. A single Option-01T will not control more than one 1260-101.

See **Chapter 2: Getting Started** for instructions on combining 1260-Series modules and Adapt-a-Switch plug-ins in the same VXIbus chassis.

Ease of Use

The 1260-100/101 includes several ease-of-use features (the 1260-100 model is shown in **Figure 1-3**):

- Plug-ins are easy to insert and extract from the front panel of the 1260-100/101, even while it is installed in a chassis.
- For only the 1260-100, module addresses, used to uniquely identify each plug-in, are set by a single DIP switch that is easily accessible from the side panel of the 1260-100. See **Setting Configuration Switches** in **Chapter 2: Getting Started** for instructions.
- The 1260-100/101 ejector handles also function as injectors, making it easy to install the carrier into a VXIbus chassis.

Maintainability

Maintainability of the 1260-100/101 is enhanced by the fact that plug-ins are removable from the front panel. This has the following benefits:

- The mean time to repair (MTTR) is minimized, since the carrier does not need to be disassembled or even removed from the VXIbus chassis.
- The switch system may be easily upgraded in the field by adding or changing plug-ins.
- Sparing is less costly and more flexible, since individual plug-ins may be spared rather than the entire 1260-100/101 module.

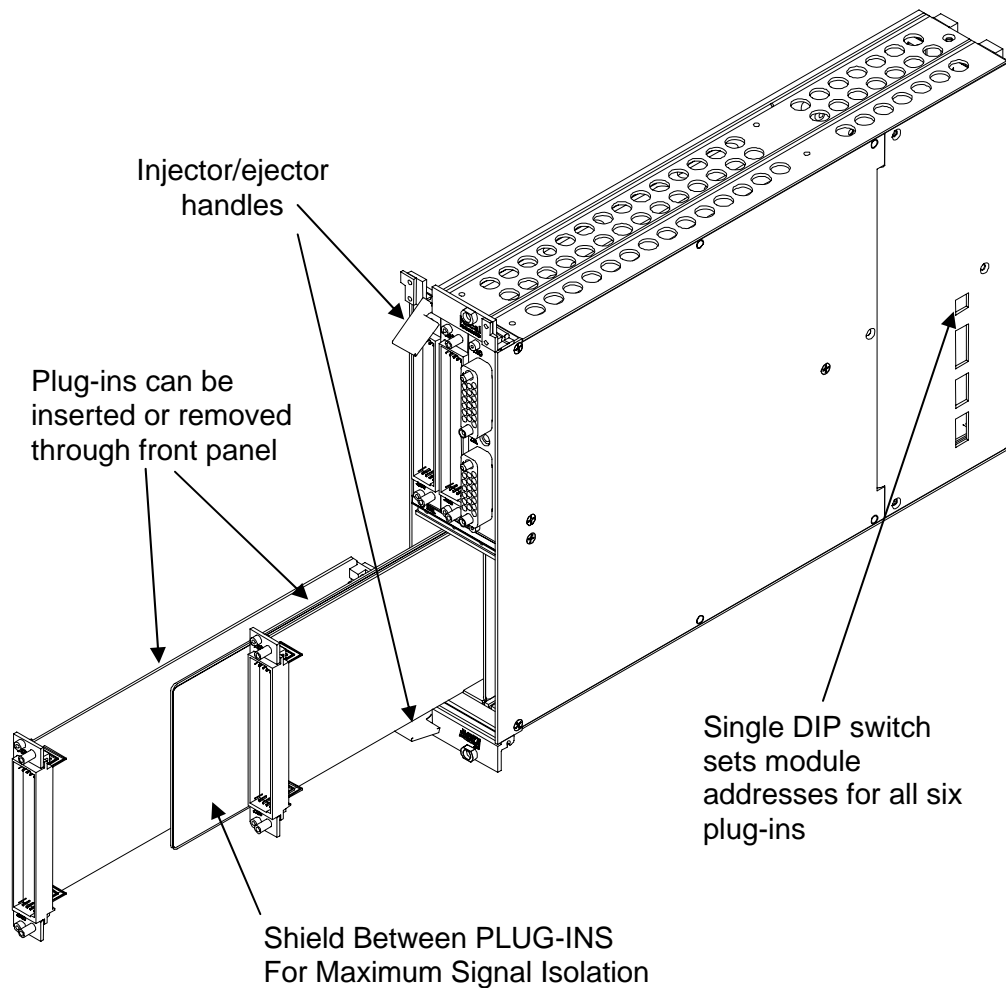

Figure 1-3, Ease-of-Use Features

Dynamically-Configured Analog Bus

The 1260-100 /101 Adapt-a-Switch Carrier offers an analog bus to interconnect two or more plug-ins. This allows the creation of large multiplexers and matrices. The analog bus may be dynamically configured under software control.

For instructions in using the analog bus, refer to the instruction manuals for the individual multiplexer and matrix plug-ins.

Chapter 2

GETTING STARTED

Unpacking and Inspection



1. Remove the 1260-100/101 module and inspect it for damage. If any damage is apparent, inform the carrier immediately. Retain shipping carton and packing material for the carrier's inspection.
2. Verify that the pieces in the package you received contain the correct 1260-100/101 module option and the 1260-100/101 Users Manual. Notify EADS North America Defense Test and Services, Inc. if the module appears damaged in any way. Do not attempt to install a damaged module into a VXI chassis.
3. The 1260-100/101 module is shipped in an anti-static bag to prevent electrostatic damage to the module. Do not remove the module from the anti-static bag unless it is in a static-controlled area.

CAUTION:

ESD sensitive devices, open the instrument at an ESD safe work station.

Reshipment Instructions

1. Use the original packing when returning the switching module to EADS North America Defense Test and Services, Inc. for calibration or servicing. The original shipping carton and the instrument's plastic foam will provide the necessary support for safe reshipment.
2. If the original packing material is unavailable, wrap the switching module in an ESD Shielding bag and use plastic spray foam to surround and protect the instrument.
3. Reship in either the original or a new shipping carton.

Option-01T

The 1260-100/101 may be ordered with or without the Option-01T. If the Option-01T is included, it controls all plug-ins inside the 1260-100/101. It may also control plug-ins in an adjacent 1260-100/101 module, or several 1260-Series modules in consecutive slots.

The following rules apply when using the Option-01T controller:

- Each Adapt-a-Switch or full-size VXI switch module has its own unique module address.
- 1260-100 assigns module addresses 1 through 12, to its module slot, depending on the position of the Address Range DIP switch.
- 1260-101 always assigns module address 1 to the top slot and 2 to the bottom slot.
- Full-size VXI switch cards may be assigned any module address from 1 to 12, inclusive, selectable by the DIP switch.
- To be controlled by a single Option-01T, a group of switch modules and carriers must be installed in a contiguous group of VXIbus chassis slots and the Option-01T must be installed in the left-most module in the group.
- Any 1260-100/101 Carrier or 1260-Series module that is not equipped with an Option-01T must have the Local Bus Jumper Assembly (P/N 405951) and Bus Grant Jumper Assembly (P/N 405951-003) installed in its place. This ensures that the Local Bus and Bus Grant daisy chains are unbroken.

Below are some examples of possible configurations:

Example 1:

A single Option-01T may control all Adapt-a-Switch plug-ins in one or two 1260-100 Carriers. When it controls two carriers, the carriers must be in adjacent slots in the VXIbus chassis, with the Option-01T-equipped carrier in the left-most slot of the group.

A single Option-01T may control all Adapt-a-Switch plug-ins in a 1260-101 and 1260-100 Carriers. When it controls two carriers, the carriers must be in adjacent slots in the VXIbus chassis, with the Option-01T-equipped carrier in the left-most slot of the group. A single option_01T will not control more than one 1260-101.

Example 2:

A single Option-01T may control a group of 1260-Series switch modules. The modules must be installed in a contiguous group of slots in the VXIbus chassis.

Example 3:

A single Option-01T may control a mixed group of 1260-Series switch modules and Adapt-a-Switch plug-ins. The maximum number of items in each group is twelve. Each 1260-100 carrier counts as six plug-ins and each 1260-101 carrier counts as two plug-ins, regardless of the quantity of plug-ins actually installed. For instance, a single Option-01T may control the following group:

- Slot 3: 1260-54 RF Switch (conventional one-slot VXI module), equipped with Option-01T
- Slots 4 and 5: 1260-100 Adapt-a-Switch carrier, containing three 1260-138 plug-ins and two 1260-150 RF switch plug-ins.
- Slot 6: 1260-22 Power Switch (conventional one-slot VXI module)
- Slot 7: 1260-22 Power Switch
- Slot 8: 1260-101 Adapt-a-Switch carrier, containing one 1260-145.

The above group counts as eleven items: the 1260-54 and 1260-22 modules count as one item each, for a total of three. The 1260-100 carrier is considered as six items, regardless of the number of plug-ins installed. The 1260-101 carrier is considered as two items. Adding these together, the total number of controlled items is eleven. This means that there is still room to add one 1260-Series switch modules to the group, with the entire group controlled by one Option-01T. The Option-01T must be installed in the 1260-54 module in slot 3. In the case where an Option-01T controls plug-ins residing in two adjacent carriers, the Option-01T must be installed in the carrier on the left.

For groups that are larger than twelve, additional Option-01T modules are used.

Figure 2-1 illustrates the installation of an Option-01T into a 1260-100 Carrier. Follow these steps:

1. Remove the six screws that secure the access panel. Remove the access panel by sliding it away from the front panel.
2. Remove the Bridge module by pulling it straight out of the carrier.
3. Disconnect the Fail LED cable from the connector on the Mezzanine module. Next, remove the Mezzanine board by pulling it straight out of the carrier.
4. Carefully remove the Local Bus Jumper Assembly (P/N 405951) and Bus Grant Jumper Assembly (P/N 405951-003) from the Mezzanine board, taking care not to bend the connector pins. Store these in a safe place in case the Option-01T needs to be relocated later.
5. Position the Option-01T over the Mezzanine board, so that connectors P3 and P4 on the Option-01T align with Mezzanine connectors J1 and J2, respectively. Press the Option-01T and Mezzanine board together so that the connectors mate fully. Secure the Option 01T to the mezzanine board using the three screws included.
6. Re-install the Mezzanine board into the carrier, taking care to align its connectors with those on the carrier backplane. Connect the Fail LED cable to the three-pin plug on the Option-01T module. Polarity does not matter; it may be connected in either direction.
7. Re-install the Bridge module.
8. Re-install the access panel and secure with screws.
9. The user may want to mark the 1260-100 to indicate that the 01T is installed.

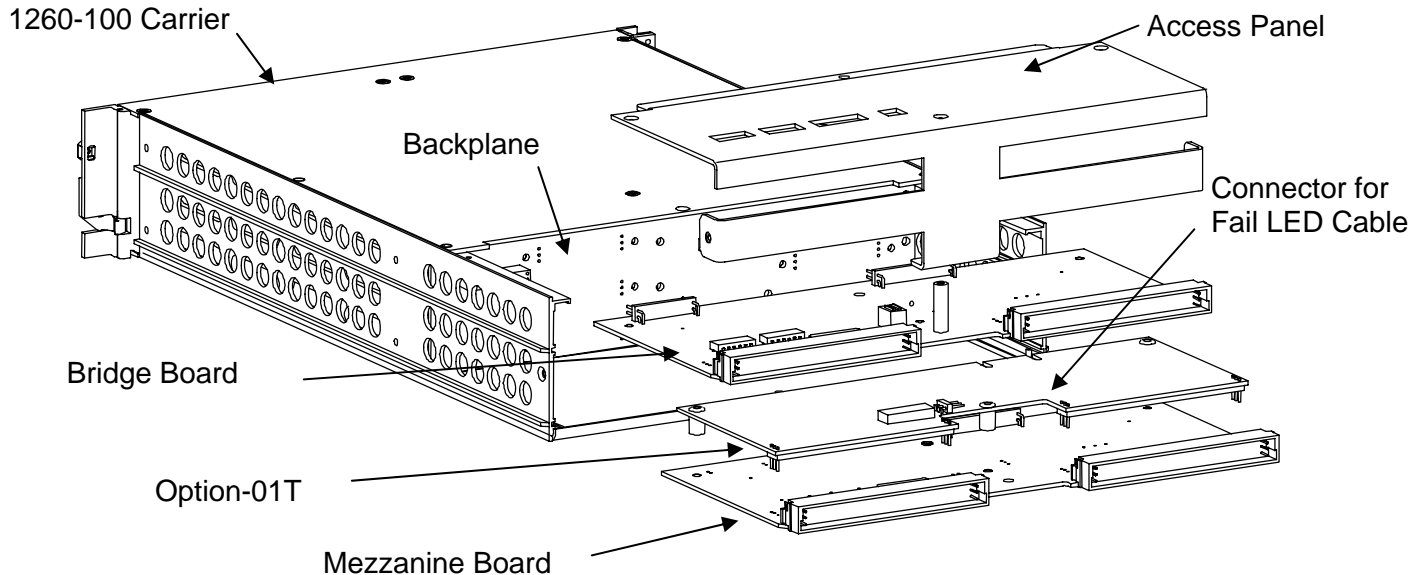

Figure 2-1, Installing the Option-01T in the 1260-100
(For the 1260-101 single-slot carrier, see text below)

For the 1260-101 follow the instructions below:

1. Remove the eight screws from the access panel. Remove the access panel.
2. Remove the three screws on the Mezzanine board. Disconnect the Fail LED cable from the connector on the Mezzanine board. Next, remove the Mezzanine board by pulling it straight out of the carrier.
3. Carefully remove the Local Bus Jumper Assembly (P/N 405951) and Bus Grant Jumper Assembly (P/N 405951-003) from the Mezzanine board, taking care not to bend the connector pins. Store these in a safe place in case the Option-01T needs to be relocated later.
4. Position the Option-01T over the Mezzanine board, so that connectors P3 and P4 on the Option-01T align with Mezzanine connectors J1 and J2, respectively. Press the Option-01T and Mezzanine board together so that the connectors mate fully. Secure the Option 01T to the mezzanine board using the three screws included.
5. Re-install the Mezzanine board into the carrier. Connect the Fail LED cable to the three-pin plug on the Option-01T module. Polarity does not matter; it may be connected in either direction.
6. Re-install the access panel and secure with screws.

7. The user may want to mark the 1260-101 to indicate that the 01T is installed.

Setting Configuration Switches

1260-100 has its configuration switches located on the right side panel (see **Figure 2-2**).

1260-101 has no module address DIP switch and the local bus daisy chain DIP switches are on the left side panel.

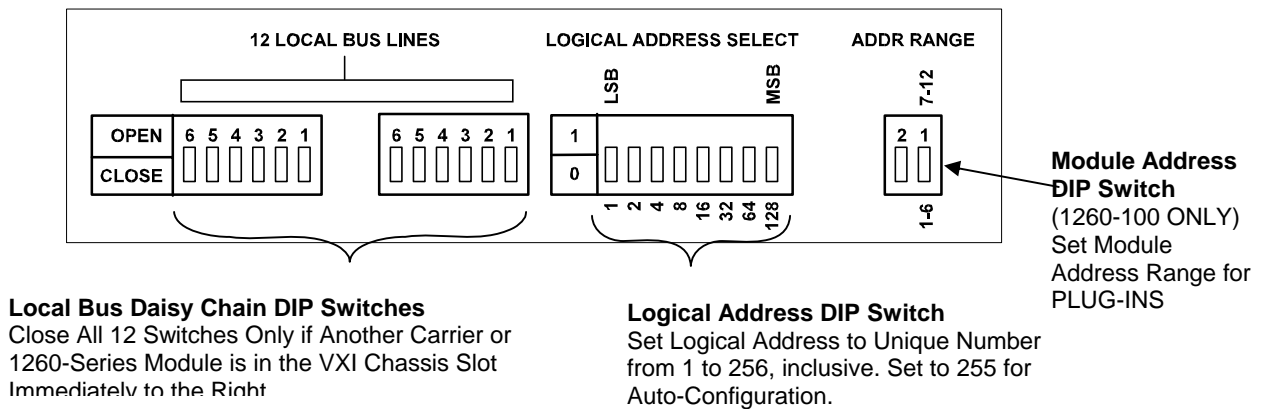

Figure 2-2, Configuration Switches

Set these switches as follows.

Local Bus Daisy-Chain Switches

If you are using a 1260-100/101 Carrier by itself, with no switch modules or carriers to its right, set all twelve local bus daisy-chain switches to the OPEN position. On the other hand, if you install a 1260-Series switch module or another 1260-100 Carrier to the immediate right, set all twelve local bus daisy-chain switches to the CLOSE position. This allows the Option-01T in the 1260-100 Carrier to control not only the plug-ins in that carrier, but the switch modules installed to the right, as well.

Logical Address Switch (only if Option-01T installed)

If an Option-01T is installed in the 1260-100/101 Carrier, an eight-segment DIP switch is visible through the opening labeled "Logical Address", as shown in **Figure 1-4**. This DIP switch sets the binary address by which the Option-01T will access the plug-ins in the carrier. Each segment represents a numeric value, as labeled, so that the combination of eight segments forms a binary number from 0 to 255₁₀.

Every module in a VXIbus chassis that is directly controlled by the

slot 0 controller must have a unique module address. The plug-ins in the 1260-100/101 Carrier, and the 1260-Series switch modules, are controlled by the Option-01T controller. Therefore, they do not need, or provide, logical addresses. Instead, the slot 0 controller communicates directly with the Option-01T only. Therefore, a single logical address covers all switch products that the Option-01T controls. You may set the Option-01T logical address switches in either of two ways:

1. Set the switch to 255. This is the auto-configure setting, and indicates to the slot 0 controller that it must assign an address automatically. When the Resource Manager program is run, the slot 0 controller will then assign a unique address to the Option-01T.
2. Set the address manually. Valid settings include any number from 1_{10} to 254_{10} . Make sure that the address does not match that of any other module installed in the same VXIbus chassis.

Module Address Switch

Although plug-ins and 1260-Series modules do not require logical addresses (the Option-01T has one instead), they each have a *module address*. The Option-01T uses module addresses to distinguish between plug-ins, and between 1260-Series modules.

Each plug-in or module must have a unique module address from one through twelve, inclusive. The 1260-100 and 1260-101 assign module addresses as follows:

1260-100 Module Address

The module address DIP switch (**See Figure 2-2**) sets the logical addresses for all plug-ins in the 1260-100 Carrier. The switch has two settings:

- 1-6 (closed) When the switch is set to this position, the module addresses of the plug-ins are from 1 through 6, with 1 being in the left slot of the top row. The plug-ins are addressed in the following pattern:

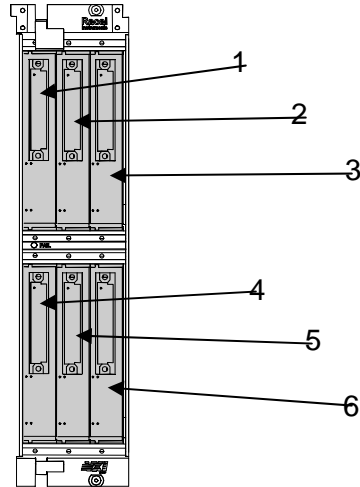

The Front View – One 1260-100

- 7-12 (open) When the switch is set to this position, the module addresses of the plug-ins are from 7 through 12, in the following pattern:

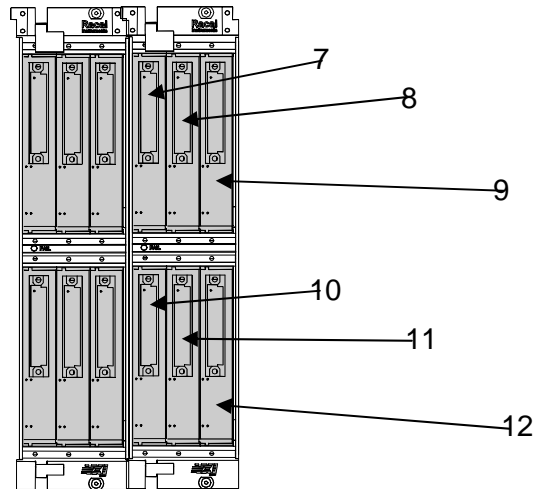

The Front View – Two 1260-100s

1260-101 Module Address

The module addresses of the two plug-ins are always 1 and 2 (the top slot is 1).

Set the module addresses for the Adapt-a-Switch Carriers and 1260-Series modules so that no address is used by more than one plug-in or 1260-Series module. For instructions on setting module addresses for a 1260-Series module, see the label on the side panel of the module, or refer to the module instruction manual.

Inserting and Removing Plug-Ins

CAUTION:

If the 1260-100/101 Carrier is in a VXIbus chassis, make sure the chassis power is off before inserting or removing plug-ins. Using proper anti-static handling procedures when plug-ins are outside the carrier.

Figure 1-3 shows how to insert or remove a plug-in. To insert a plug-in, position the module so that the edges align with the grooves in the carrier slot. Slide the plug-in all the way into the carrier, then press firmly to engage its connector with the carrier backplane. Tighten the plug-in retaining screws securely.

To remove a plug-in, loosen the two retaining screws until they float freely. Since they are captive, they do not come completely out. Pull firmly and evenly on the retaining screws to disengage the plug-in from the backplane, then pull the plug-in out of the carrier.

Installing the 1260-100/101 into a VXIbus Chassis

To install the 1260-100/101 Carrier into a VXIbus chassis, position the carrier so that the ridges at the top and bottom align with the grooves in the chassis slots (See **Figure 1-3**). As you push the carrier into the chassis, ensure that the injector/ejector handles are in the proper positions. The upper handle should be all the way up, and the lower handle should be all the way down. Push the carrier into the chassis until it stops. Then use the injector/ejector handles to engage the carrier with the chassis backplane. Simultaneously push the upper handle downward and the lower handle upward until the carrier is fully inserted. Tighten the upper and lower retaining screws.

To remove the 1260-100/101 Carrier from the VXIbus chassis, loosen the upper and lower retaining screws. Simultaneously push the upper injector handle upward and pull the lower handle downward until the carrier is disengaged from the chassis backplane. Then slide the carrier out of the chassis.

Making Connections to Plug-Ins (Pin-Outs)

For information about connecting external equipment to the plug-ins, refer to the individual manuals for the plug-ins. These include information regarding mating connector part numbers, pinouts, and electrical ratings.

Power-On Self-Test

When the VXIbus chassis is switched on, the Option-01T automatically runs a self-test. While this self-test is running, the Fail LED on the front panel of the carrier illuminates. **Figure 1-7** shows the location of the Fail indicator. If the carrier is not equipped with an Option-01T, the Fail LED will not illuminate.

When the Option-01T completes self-test, the Fail LED will extinguish. This occurs within five seconds after chassis power is turned on.

The self-test includes the following:

1. PROM checksum
2. RAM write/read pattern verification
3. Microprocessor instruction test
4. Non-volatile RAM verification
5. Timer test

This self-test represents 70% fault detection.

Closing and Opening Relays

For general commands to close and open relays, refer to the section **Closing a Relay** in **Chapter 1: Getting Started** of the Option-01T Instruction Manual. Other commands are specific to individual plug-ins. For detailed information on module-specific commands, refer to the instruction manual for the appropriate plug-in.

Checking the Response of Plug-Ins

To verify that the plug-ins are operational, send the `MOD:LIST?` command to the Option-01T. Then read back the response of the Option-01T. The Option-01T responds with a message specifying which plug-ins and 1260-Series modules are under its control. If the Option-01T does not respond, or does not properly list the installed switch products, refer to **Appendix C: Troubleshooting**.

Closing and Opening Relays

To use the message-based mode of communication, refer to Chapter 2 of the Option-01T Instruction Manual for general commands. For module-specific commands, refer to the individual manuals for the plug-ins.

For high-speed operation, use the register-based mode with *VXIplug&play* drivers. For detailed information, refer to the **VISA and the VXIplug&play Software** section of **Chapter 2: Using the Option-01T** in the Option-01T Instruction Manual.

Emergency Reset Function

Description

To enhance safety in applications that involve power switching, certain Adapt-a-Switch plug-ins and conventional 1260-Series modules offer an emergency reset function, activated by an external input. This function instantly opens all relays in response to an external event. This is a hardware operation that does not require intervention on the part of the Option-01T or application software.

When using the emergency reset feature, exercise due caution if any undesirable effects may result from opening all channels.

Interface

Select Adapt-a-Switch plug-ins and 1260-Series modules have a pair of front-panel-mounted connector pins. You may connect these to an external device such as a mechanical switch. When the switch is opened, all relays on the plug-in or module are immediately opened.

An example of a plug-in that provides the emergency switch interface is the 1260-120 Power Switch. All other plug-ins and 1260-Series modules that provide the switch interface operate in the same manner as the 1260-120.

Normal State of External Switch

If desired, a jumper setting on the plug-ins allows it to accommodate a normally-closed external switch. Normally-open is the default. Refer to the individual plug-in manual.

Scope of Reset Event

The 1260-120 design allows the scope of an emergency reset to be configured. In the default configuration, the 1260-120 opens only its own relays in response to an external reset event. If desired, a jumper setting on the 1260-120 may be changed so that the effect of an emergency reset is global. With the global reset configuration, a reset signal propagates through the VXI Local Bus to open all relays on all switch products that are connected to the same Option-01T.

All 1260-Series and Adapt-a-Switch plug-ins respond to an emergency reset condition when the scope is set to global. Certain plug-ins and 1260-Series modules provide the front-panel contacts for the external switch, and the circuitry to recognize a reset event. A switch system may make full use of the emergency reset feature if it includes at least one plug-in or 1260-Series module that has reset recognition capability.

Sequence of Events

When a reset event occurs, the following sequence takes place:

1. The plug-in that is connected to the external switch recognizes the reset event and sets a logic latch.
2. All relays are opened on the switch product that recognized the reset event. If the scope of the reset function is set to global, then all relays on all switch products connected to the same Option-01T are also opened. This happens independently of software.

3. An interrupt is generated to notify the Option-01T that a reset event has occurred. This informs the Option-01T that the relays have opened, so that it remains up-to-date on the relay status.
4. The relays remain open and do not respond to any commands from the Option-01T.
5. After the reset condition is removed (the external switch is returned to its normal position), the relays remain open until otherwise commanded by the Option-01T.

Other Adapt-a-Switch plug-ins and 1260-Series modules that are equipped to recognize an emergency reset are configured and operate the same way as the 1260-120. It is important to note that a global reset condition opens relays on all plug-ins and 1260-Series modules that are connected to the same Option-01T, regardless of whether they are equipped with the interface for the external reset switch.

This page was left intentionally blank.

Chapter 4

MAINTENANCE

Performance Verification Procedure

Purpose

The following procedure verifies the basic functions of the 1260-100/101 Adapt-a-Switch Carrier. Test coverage includes:

- Option-01T power-on self-test
- Option-01T basic operation in message based mode
- Option-01T operation in register-based mode
- 1260-100/101 receive and transmit functions

Equipment Required

- VXIbus chassis
- Embedded slot 0 controller, or MXI slot 0 controller with IBM-compatible PC

Software Required

- Microsoft Windows 95 or NT
- VXI Resource Manager (RESMAN) by National Instruments
- VXI Interactive Control (VIC) by National Instruments

Procedure

1. Ensure that an Option-01T is installed in the carrier as outlined in the **Option-01T** section of **Chapter 2: Getting Started**.
2. Set the logical address switch to 3.
3. Set the module address switch to the 1-6 position.

4. Install the carrier into an empty pair of slots in a VXIbus chassis. Remove all other modules from the chassis except the slot 0 controller.
5. Insert one or more plug-ins into the 1260-100/101 Carrier.
6. Turn the chassis power on. Verify that the Fail LED on the carrier illuminates, then extinguishes within five seconds.
7. Run the National Instruments Resource Manager program (RESMAN). From the RESMAN output log file, verify the following:
8. The Option-01T is recognized as DEVICE_3.
9. The self-test for DEVICE_3 passed.
10. 16K-bytes of memory are allocated for DEVICE_3.
11. Start the VXI Interactive Control (VIC) program (by National Instruments).
12. Send a *IDN? command to DEVICE_3 (Option-01T).
13. Read the response from the Option-01T. Verify that the response is of the form:
14. Racal Instruments,1260A Option-01T,<serial num>,<revision>
15. Where <serial num> is the serial number, and <revision> is the revision level of the firmware.
16. Click on the Bus Access feature of VIC. Select the WRITE mode.
17. Calculate the address offset of one of the Adapt-a-Switch plug-ins. To do this, begin with the address reported by RESMAN as being the starting address for DEVICE_3. Add 1. Then add 400_{16} times the module address of the plug-in. Enter this address into the ADDRESS field in VIC.
18. Select the A24 address mode.
19. In the data field, enter 55_{16} . Click on GO. If the plug-in is a relay type (not a digital type), you should hear the relays close.
20. Select the READ mode, set the number of bytes to at least 1, and click on GO. Verify that the Option-01T

responds with AA_{16} , which is the one's compliment of the data written.

21. In the data field, enter AA_{16} . Click on GO. If the plug-in is a relay type (not a digital type), you should hear the relays open.
22. Select the READ mode, set the number of bytes to at least 1, and click on GO. Verify that the Option-01T responds with 55_{16} , which is the one's compliment of the data written.
23. Repeat steps 12 through 17 for each of the remaining plug-ins.
24. Turn the chassis power switch off.
25. If fewer plug-ins are available than the number of slots, repeat steps 5 through 18 with the plug-ins in different slots until all carrier slots have been tested.
26. For the 1260-100 set the module address switch on the carrier to the 7-12 position. Repeat steps 5 through 20. When calculating the address offset in step 12, remember that the module addresses now range from 7 through 12.

This page was left intentionally blank.

Chapter 5

PRODUCT SUPPORT

Product Support

EADS North America Defense Test and Services, Inc. has a complete Service and Parts Department. If you need technical assistance or should it be necessary to return your product for repair or calibration, call 1-800-722-3262. If parts are required to repair the product at your facility, call 1-949-859-8999 and ask for the Parts Department.

When sending your instrument in for repair, complete the form in the back of this manual.

For worldwide support and the office closest to your facility, refer to the website for the most complete information <http://www.eads-nadefense.com>.

Warranty

Use the original packing material when returning the 1260-100/101 to EADS North America Defense Test and Services, Inc. for calibration or servicing. The original shipping container and associated packaging material will provide the necessary protection for safe reshipment.

If the original packing material is unavailable, contact EADS North America Defense Test and Services, Inc. Customer Service at 1-800-722-3262 for information.

REPAIR AND CALIBRATION REQUEST FORM

To allow us to better understand your repair requests, we suggest you use the following outline when calling and include a copy with your instrument to be sent to the EADS North America Defense Test and Service, Inc. Repair Facility.

Model _____ Serial No. _____ Date _____

Company Name _____ Purchase Order # _____

Billing Address _____

City

State/Province

Zip/Postal Code

Country

Shipping Address _____

City

State/Province

Zip/Postal Code

Country

Technical Contact _____ Phone Number () _____

Purchasing Contact _____ Phone Number () _____

1. Describe, in detail, the problem and symptoms you are having. Please include all set up details, such as input/output levels, frequencies, waveform details, etc.

2. If problem is occurring when unit is in remote, please list the program strings used and the controller type.

3. Please give any additional information you feel would be beneficial in facilitating a faster repair time (i.e., modifications, etc.)

4. Is calibration data required? Yes No (please circle one)

Call before shipping
Note: We do not accept
"collect" shipments.

Ship instruments to nearest support office.

Appendix A

1260 SPECIFICATIONS

General

1260 Series Compatibility	Option-01T simultaneously controls combination of Adapt-a-Switch plug-ins and 1260-Series switch modules
Annunciators	FAIL: Self-test failure indicator LED
Host Interface	VXIbus backplane
Control Type	Message-based. Register based: VXIbus A24 address space.
Switching Response Time*	
Register-based:	9 μ s max.
Message-based:	10 ms typ.
VXI Plug&Play	Compatible drivers for all 1260-Series switching modules

Mechanical

Size	VXIbus C-size, two-slot module
Module Capacity	Six Adapt-a-Switch plug-ins
Weight (empty carrier)	Weight: 4.4 lbs (2.0 kg)
Front-Panel Connectors	Provided by each plug-in switch card

Electrical

Indicators	Fail indicator, red LED
RF Shielding	Fixed steel shields between plug-in slots
Analog Bus	Four two-wire channels 100-ohm impedance, 2A current capacity

Power and Cooling

Power Consumption (without plug-ins)	+5V: 1.0A +12V: 0A +24V: 0A
Power Available (per plug-in)	+5V: 2.5A +12V: 1.0A +24V: 1.0A
Cooling (worst-case plug-in configuration)	Airflow: 3.0 liters/sec Backpressure: 0.7 mm H ₂ O

Environmental

Temperature	Operating: 0°C to +55°C Non-operating: -40°C to +70°C
Relative Humidity	95% RH non-condensing
Altitude	Operating: 10,000 ft. Non-operating: 15,000 ft.
Vibration	0.013 in. P-P, 5 Hz to 55 Hz; meets MIL-T-28800C Type III, Class 5, Style F
Shock	30g, 11 ms, 1/2 sine wave
Bench Handling	4 inch drop at 45°

EMC and Safety

Emissions	EN61326: 1997+A1:1998, Class A
Susceptibility, Safety	EN61010-1:1993+A2:1995

Reliability

Mean Time Between Failures (MTBF)	315,749 hours, MIL-HBK-217, ground-benign, 30°C
Mean Time To Repair (MTTR)	Replace plug-in: 5 min. Replace other: <30 min.

*Measured from start of VXIbus cycle until relay coil is fully energized.

General

1260 Series Compatibility	Option-01T simultaneously controls combination of Adapt-a-Switch plug-ins and 1260-Series switch modules
Annunciators	FAIL: Self-test failure indicator LED
Host Interface	VXIbus backplane
Control Type	Message-based. Register based: VXIbus A24 address space.
Switching Response Time*	
Register-based:	9 μ s max.
Message-based:	10 ms typ.
VXI Plug&Play	Compatible drivers for all 1260-Series switching modules

Mechanical

Size	VXIbus C-size, single-slot module
Module Capacity	Two Adapt-a-Switch plug-ins
Weight (empty carrier)	Weight: 2.42 lbs
Front-Panel Connectors	Provided by each plug-in switch card

Electrical

Indicators	Fail indicator, red LED
RF Shielding	Fixed steel shields between plug-in slots
Analog Bus	Four two-wire channels 100-ohm impedance, 2A current capacity

Power and Cooling

Power Consumption (without plug-ins)	+5V: 1.0A +12V: 0A +24V: 0A
Power Available (per plug-in)	+5V: 4.5A +12V: 0.75A +24V: 0.75A
Cooling (worst-case plug-in configuration)	Airflow: 1.5 liters/sec Backpressure: 0.7 mm H ₂ O

Environmental

Temperature	Operating: 0°C to +55°C Non-operating: -40°C to +70°C
Relative Humidity	95% RH non-condensing
Altitude	Operating: 10,000 ft. Non-operating: 15,000 ft.
Vibration	0.013 in. P-P, 5 Hz to 55 Hz; meets MIL-T-28800C Type III, Class 5, Style F
Shock	30g, 11 ms, 1/2 sine wave
Bench Handling	4 inch drop at 45°

EMC and Safety

Emissions	EN61326: 1997+A1:1998, Class A
Susceptibility, Safety	EN61010-1:1993+A2:1995

Reliability

Mean Time Between Failures (MTBF)	>315,749 hours, MIL-HBK-217, ground-benign, 30°C
Mean Time To Repair (MTTR)	Replace plug-in: 5 min. Replace other: <30 min.

*Measured from start of VXIbus cycle until relay coil is fully energized.

Appendix B

1260-101 THEORY OF OPERATION

Mezzanine PCB Assembly

The Mezzanine is built from the same bare PCB as the Bridge. The difference is in the components installed. One schematic (P/N 435138,-001) covers both the Mezzanine and Bridge.

General

The Mezzanine PCB serves two functions. It connects +5V, +12V, and +24V power from the VXIbus backplane to the 1260-100 backplane. It also connects the VXIbus backplane signals to the Option-01T if it is installed.

Power Filtering

The power is filtered before reaching either the backplane or Option-01T. The fuses, F1 through F3, are of the surface-mount type. The fuses used are as follows.

FUSE	MANUFACTURER	MANUFACTURER'S PART NUMBER	RATING (AMPS)	PART NUMBER
F1	Wickmann USA, Inc.	418 2100000	10	921545
F2	Wickmann USA, Inc.	417 1315000	3.15	921546
F3	Wickmann USA, Inc.	417 1315000	3.15	921546

Signal Connections

Connectors P1 and P2 connect to the VXIbus backplane. Connectors J1 and J2 connect to the Option-01T.

The Option-01T accesses the VXI Local Bus via J2C (third row of connector J2). These signals go through the zero-ohm resistors R7 through R18 before reaching P2. From P2, the local bus signals go to the Bridge module, which uses them to interface the Option-01T to the plug-ins.

DIP switches S1 and S2 are not installed on the Mezzanine. Instead, resistors R7 through R18 make the equivalent connections instead.

If an Option-01T is not installed on the Mezzanine, then the Local Bus Jumper Assembly (P/N 405951) must be installed onto connector J2. The local bus signals from an external Option-01T then flow through the Mezzanine as follows: The signals enter the Mezzanine on P2A (P2, row A). The Mezzanine connects them to J2A. The jumper assembly then connects them to J2C. The Mezzanine connects them to P2C, which connects to the VXI backplane. The Bridge then connects to these signals using its P2 connector.

Unlike the 1260-Series switch modules, it is not necessary to install the Bus Grant Jumper Assembly (P/N 405951-003) on connector J1 when the Option-01T is not installed. This is because the Mezzanine provides the same connections on P1B. However, installing the Bus Grant Jumper Assembly causes no problems.

Power Distribution

The backplane distributes power from the Mezzanine and Bridge to the six plug-in slots.

Signals

The backplane provides a signal path between the plug-ins and the Bridge. All communications signals are connected in parallel to all six plug-ins, except LBOARDSEL1 through LBOARDSEL6. These six signals route to their respective plug-in slots, and identify which plug-in is currently addressed.

The backplane also provides an analog bus. This bus consists of four pairs of PCB traces that daisy-chain from one plug-in to the next, connecting to all six slots in parallel. Each pair of traces is impedance-matched to 100 ohms, and is routed for maximum isolation and minimum crosstalk.

Bridge PCB Assembly

Local Bus Signal Routing

The Bridge provides the circuitry to interface between the plug-ins and the Option-01T. It receives the local bus signals from the Option-01T on connector P2A. The zero-ohm resistors R20 through R31 allow the signals to reach J2A, without the use of a Local Bus Jumper Assembly. From J2A, the signals go to the interface circuitry.

DIP switches S1 and S2 allow the Option-01T to be daisy-chained to the next VXI module to the right. If all segments of DIP switches S1 and S2 are closed, the local bus signals will also go to P2C, which connects to the VXIbus backplane. In this case, the VXI module immediately to the right of the 1260-100 Carrier has access to the local bus signals from the Option-01T. If the module to the right of the 1260-100 Carrier is not meant to be controlled by the Option-01T, then all segments of DIP switches S1 and S2 should be open.

The local bus signals LBUSC00S through LBUSC09S are differential. U2 converts LBUSC00S through LBUSC07S to TTL levels. LBUSC08S and LBUSC09S are a bidirectional differential pair. U3 and U4 receive and drive these signals, respectively.

Reset Circuit

U7 is a voltage monitor used to reset the Bridge and plug-ins at power turn-on. At power turn-on, it drives LLOGICRST low for approximately 130ms. It then takes LLOGICRST high and leaves it high, unless +5V power drops below 4.5V.

The signal LBUSC10S is an open-collector line from the Option-01T. During power turn-on, the Option-01T drives LBUSC10S low for about 100ms, then allows it to be pulled high. While LBUSC10S is low, it resets all relay drivers on all plug-ins to the inactive state, opening all relays. It also clears all outputs on digital test plug-ins to a known state.

LBUSC10S also serves another function when a plug-in asserts a global reset during an emergency reset event. When such an event occurs, the plug-in drives LBUSC10S low. It leaves it low until the event has passed and the Option-01T firmware clears the reset latch in the plug-in.

LBUSC10S also connects to all other devices controlled by the same Option-01T. When any device in this group asserts a global

reset, all devices in the group respond by resetting their drivers.

Interrupt

The signal LBUSC11S is an open-collector line to the Option-01T. It has two purposes. When a plug-in asserts an emergency reset condition, it drives the LBUSC11S signal low. Also, the 1260-114 drives the LBUSC11S signal low to announce a synchronous event. When LBUSC11S goes low, the Option-01T polls the plug-ins to determine which one generated the interrupt. It then responds accordingly.

Communications

U1 is a programmable logic device (PLD) that handles the communications between the plug-ins and the Option-01T. It implements the same state machine used in 1260-Series switch modules. Communications proceed as follows.

When the Option-01T is about to write data to a plug-in, it takes HLBUS_A/D to a logic 1, indicating that the data to be serially shifted out will be an address. It also drives the HLBUS_R/W signal low to indicate that data will be written. It then outputs an 8MHz clock on HLBUS_CLK, and places serial data on HLBUS_DATAIN, synchronous with HLBUS_CLK. The first 13 bits of data represent the address to be written to, with the most-significant bit first. This address is relative to the A24 address offset assigned to the Option-01T by RESMAN. For example, address 0 references the first address in the space allocated to the Option-01T.

The 13 address bits are clocked into a shift register comprised of U5 and U6. The parallel outputs of this shift register are connected directly to all six plug-ins via the 1260-100 backplane.

After sending the address, The Option-01T drives HLBUS_A/D low, indicating that the next data sent will be data. It then shifts the serial data that will be written to the address just sent. There are eight data bits, with the most-significant bit sent first.

After the last data bit has been sent, the signal HLBUS_STROBE transitions to a logic high for one clock period of HLBUS_CLK. HLBUS_STROBE is sent to the six plug-ins. The plug-in containing the addressed device uses HLBUS_STROBE to latch the data into the device.

To read data from a plug-in, the Option-01T begins by taking HLBUS_A/D to a logic 1, indicating that the data to be serially shifted out will be an address. It also drives the HLBUS_R/W

signal high to indicate that data will be read. It then outputs an 8MHz clock on HLBUS_CLK, and shifts the address out on HLBUS_DATAIN, as it does when writing.

The 13 address bits are clocked into U5 and U6, as when writing. After sending the address, the Option-01T drives the HLBUS_A/D low, indicating that it is ready for data. The plug-in containing the addressed device begins shifting serial data onto HLBUS_DATAOUT. There are eight data bits, with the most-significant bit sent first.

The signal HLBUS_STROBE is used only when writing, not when reading. During reading, it remains at logic 0.

Power Distribution

The Bridge PCB connects +5V, +12V, and +24V power from the VXIbus backplane to the 1260-100 backplane to add to the current provided by the Mezzanine.

The bridge also filters power in the same manner as the Mezzanine.

PLD Programming Connector

J5 is a 10-pin header that is connected to the PLD (U1). It uses the JTAG interface to allow in-system programming of the PLD during upgrades or troubleshooting.

General

Power Filtering

The power is filtered before reaching either the backplane or Option-01T. The fuses, F1 through F3, are of the surface-mount type. The fuses used are as follows.

FUSE	MANUFACTURER	MANUFACTURER'S PART NUMBER	RATING (AMPS)	PART NUMBER
F1	Wickmann USA, Inc.	418 2100000	10	921545
F2	Wickmann USA, Inc.	417 1315000	3.15	921546
F3	Wickmann USA, Inc.	417 1315000	3.15	921546

Signal Connections

Connectors P1 and P2 connect to the VXIbus backplane. Connectors J1 and J2 connect to the Option-01T.

The Option-01T accesses the VXI Local Bus via J2C (third row of connector J2). From P2, the local bus signals go to the Mezzanine module, which uses them to interface the Option-01T to the plug-ins.

If an Option-01T is not installed on the Mezzanine, then the Local Bus Jumper Assembly (P/N 405951) must be installed onto connector J2. The local bus signals from an external Option-01T then flow through the Mezzanine as follows: The signals enter the Mezzanine on P2A (P2, row A). The Mezzanine connects them to J2A. The jumper assembly then connects them to J2C. The Mezzanine connects them to P2C, which connects to the VXI backplane.

Unlike the 1260-Series switch modules, it is not necessary to install the Bus Grant Jumper Assembly (P/N 405951-003) on connector J1 when the Option-01T is not installed. This is because the Mezzanine provides the same connections on P1B. However, installing the Bus Grant Jumper Assembly causes no problems.

Power Distribution

The Mezzanine distributes power the two plug-in slots.

Signals

All communications signals are connected in parallel to the two plug-ins, except LBOARDSEL1 and LBOARDSEL2. These two signals route to their respective plug-in slots, and identify which plug-in is currently addressed.

The Mezzanine also provides an analog bus. This bus consists of four pairs of PCB traces that daisy-chain from one plug-in to the next, connecting to the two slots in parallel. Each pair of traces is impedance-matched to 100 ohms, and is routed for maximum isolation and minimum crosstalk.

Mezzanine PCB Assembly

Local Bus Signal Routing

The Mezzanine connects +5V, +12V, and +24V power from the VXIbus backplane to the plug-ins and connects the VXIbus backplane signals to the Option-01T if it is installed.

The Mezzanine also provides the circuitry to interface between the plug-ins and the Option-01T. It receives the local bus signals from the Option-01T on connector P2A. From J2A, the signals go to the interface circuitry.

DIP switches S1 and S2 allow the Option-01T to be daisy-chained to the next VXI module to the right. If all segments of DIP switches S1 and S2 are closed, the local bus signals will also go to P2C, which connects to the VXIbus backplane. In this case, the VXI module immediately to the right of the 1260-101 Carrier has access to the local bus signals from the Option-01T. If the module to the right of the 1260-101 Carrier is not meant to be controlled by the Option-01T, then all segments of DIP switches S1 and S2 should be open.

The local bus signals LBUSC00S through LBUSC09S are differential. U2 converts LBUSC00S through LBUSC07S to TTL levels. LBUSC08S and LBUSC09S are a bidirectional differential pair. U3 and U4 receive and drive these signals, respectively.

Reset Circuit

U7 is a voltage monitor used to reset the Mezzanine and plug-ins at power turn-on. At power turn-on, it drives LLOGICRST low for approximately 130ms. It then takes LLOGICRST high and leaves it high, unless +5V power drops below 4.5V.

The signal LBUSC10S is an open-collector line from the Option-01T. During power turn-on, the Option-01T drives LBUSC10S low for about 100ms, then allows it to be pulled high. While LBUSC10S is low, it resets all relay drivers on all plug-ins to the inactive state, opening all relays. It also clears all outputs on digital test plug-ins to a known state.

LBUSC10S also serves another function when a plug-in asserts a global reset during an emergency reset event. When such an event occurs, the plug-in drives LBUSC10S low. It leaves it low until the event has passed and the Option-01T firmware clears the reset latch in the plug-in.

LBUSC10S also connects to all other devices controlled by the same Option-01T. When any device in this group asserts a global reset, all devices in the group respond by resetting their drivers.

Interrupt

The signal LBUSC11S is an open-collector line to the Option-01T. It has two purposes. When a plug-in asserts an emergency reset condition, it drives the LBUSC11S signal low. Also, the 1260-114 drives the LBUSC11S signal low to announce a synchronous event. When LBUSC11S goes low, the Option-01T polls the plug-ins to determine which one generated the interrupt. It then responds accordingly.

Communications

U1 is a programmable logic device (PLD) that handles the communications between the plug-ins and the Option-01T. It implements the same state machine used in 1260-Series switch modules. communications proceed as follows.

When the Option-01T is about to write data to a plug-in, it takes HLBUS_A/D to a logic 1, indicating that the data to be serially shifted out will be an address. It also drives the HLBUS_R/W signal low to indicate that data will be written. It then outputs an 8MHz clock on HLBUS_CLK, and places serial data on HLBUS_DATAIN, synchronous with HLBUS_CLK. The first 13 bits of data represent the address to be written to, with the most-significant bit first. This address is relative to the A24 address offset assigned to the Option-01T by RESMAN. For example, address 0 references the first address in the space allocated to the Option-01T.

The 13 address bits are clocked into a shift register comprised of U5 and U6. The parallel outputs of this shift register are connected directly to the two plug-ins.

After sending the address, The Option-01T drives HLBUS_A/D low, indicating that the next data sent will be data. It then shifts the serial data that will be written to the address just sent. There are eight data bits, with the most-significant bit sent first.

After the last data bit has been sent, the signal HLBUS_STROBE transitions to a logic high for one clock period of HLBUS_CLK. HLBUS_STROBE is sent to the two plug-ins. The plug-in containing the addressed device uses HLBUS_STROBE to latch the data into the device.

To read data from a plug-in, the Option-01T begins by taking HLBUS_A/D to a logic 1, indicating that the data to be serially shifted out will be an address. It also drives the HLBUS_R/W signal high to indicate that data will be read. It then outputs an 8MHz clock on HLBUS_CLK, and shifts the address out on HLBUS_DATAIN, as it does when writing.

The 13 address bits are clocked into U5 and U6, as when writing. After sending the address, the Option-01T drives the HLBUS_A/D low, indicating that it is ready for data. The plug-in containing the addressed device begins shifting serial data onto HLBUS_DATAOUT. There are eight data bits, with the most-significant bit sent first.

The signal HLBUS_STROBE is used only when writing, not when reading. During reading, it remains at logic 0.

PLD Programming Connector

J5 is a 10-pin header that is connected to the PLD (U1). It uses the JTAG interface to allow in-system programming of the PLD during upgrades or troubleshooting.

This page was left intentionally blank.

Appendix C

TROUBLESHOOTING

If you have difficulty in using the 1260-100/101 Adapt-a-Switch Carrier or its plug-ins, refer to the following troubleshooting table. If you are still unable to resolve the problem, contact one of the Customer Support offices listed in **Chapter 5: Support Offices**.

Troubleshooting Table

PROBLEM	POSSIBLE CAUSES	WHAT TO DO
FAIL indicator does not come on when chassis power is turned on.	<ul style="list-style-type: none"> • Option-01T not installed correctly. • Fail LED cable not connected properly to Option-01T. <p>Remember: Fail LED is operational only on module containing Option-01T.</p>	<ul style="list-style-type: none"> • Review Installing the Option-01T in Chapter 2: Getting Started • Verify that cable is correctly connected. See Installing the Option-01T in Chapter 2: Getting Started.
FAIL indicator stays on after self-test is completed.	<ul style="list-style-type: none"> • Option-01T defective. 	<ul style="list-style-type: none"> • Contact EADS Customer Support (see Chapter 5: Customer Support).
No response from plug-in via VXIbus.	<ul style="list-style-type: none"> • Option-01T not installed, or installed in incorrect module. • Module addresses conflicting. • Plug-in not fully seated. • Communication problem with Option-01T, 1260-100/101 Carrier, or plug-in. 	<ul style="list-style-type: none"> • Option-01T must be installed in left-most carrier or 1260-Series module in group. See Option-01T in Chapter 2: Getting Started. • Ensure that each plug-in and 1260-Series module has its own unique module address. See Module Address Switch in Chapter 2: Getting Started. • Ensure that plug-in is firmly engaged. • See special troubleshooting procedure below, entitled "Communications Troubleshooting"

PROBLEM	POSSIBLE CAUSES	WHAT TO DO
Plug-in does not appear in VXI <i>plug&play</i> soft panel list.	<ul style="list-style-type: none"> Soft panel driver not installed. Communication problem with Option-01T, 1260-100/101 Carrier, or plug-in. 	<ul style="list-style-type: none"> Install 1260 Soft Front Panel Driver. See special troubleshooting procedure below, entitled "Communications Troubleshooting".
Switch modules to the right of the 1260-100/101 do not appear in VXI <i>plug&play</i> soft panel list (1260-100/101 plug-ins do appear).	<ul style="list-style-type: none"> Local Bus daisy-chain switches not closed. 	<ul style="list-style-type: none"> Close all twelve Local Bus daisy-chain switches on 1260-100/101 Carrier when another carrier or 1260-Series module is installed to its immediate right.
Relays do not close when commanded, but plug-in appears in VXI <i>plug&play</i> soft panel list.	<ul style="list-style-type: none"> Emergency reset function activated 	<ul style="list-style-type: none"> If external switch is connected, ensure that it is in the inactive position. See the Emergency Reset Function section in Chapter 3.

Communications Troubleshooting

Try the following procedure if you have trouble operating the Option-01T or plug-ins. If you still have difficulty, contact EADS Customer Support **Chapter 5: Product Support**.

1. Turn off the VXIbus chassis power switch. Wait at least two seconds, then turn it back on. The Fail LED on the left-most 1260-100/101 Carrier or 1260-Series module should illuminate, then go out within five seconds. If it does, then proceed to step 2. If the Fail LED does not illuminate when power is turned on, then go to step 6. If the Fail LED illuminates, and stays on after five seconds, then the Option-01T may be defective; contact EADS Customer Support.
2. Send a *IDN? command to the Option-01T, then read the response. It should be in the following format:

```
Racal Instruments,1260A Option-01T,<serial num>,<revision>
```

where <serial num> is the serial number, and <revision> is the revision level of the firmware. If the Option-01T responds with a message in this form, then proceed to step 3. Otherwise, go to step 8.

3. Execute the 1260-Series soft front panel program. It should display a list of all plug-ins and 1260-Series modules that are connected to the Option-01T. If it does not display a list, then go to step 8. Otherwise, proceed with step 4.
4. If the list displayed in step 3 is complete, then go to step 5. Otherwise, go to step 10.
5. Since the list of plug-ins is complete, the Option-01T is successfully communicating with all of the plug-ins. If you still have other communication difficulties, contact EADS Customer Support.

Fail LED does not come on:

6. Verify that the Option-01T is installed in the appropriate 1260-100 Carrier or 1260-Series module as described in **Option-01T in Chapter 2: Getting Started**. Remember, the only Fail LED that will illuminate is the one on the module containing the Option-01T.
7. Verify that the Fail LED cable is properly connected to the Option-01T. If the Fail LED is not properly connected, then connect it and go back to step 1. If the Fail LED is properly connected and the Fail LED still does not illuminate, then contact EADS Customer Support.

Incorrect response or no response from Option-01T:

8. Verify that the logical address to which you communicate matches the logical address DIP switch setting on the Option-01T.
9. If this fails to correct the problem, then contact EADS Customer Support.

Incomplete module list:

10. Review the **Option-01T** section in **Chapter 2: Getting Started**. Verify that:
 - The Option-01T is installed in the appropriate 1260-100/101 Carrier or 1260-Series module.

- The logical address of the Option-01T is either set to 255 or to an address that is unique from that of any other module installed in the same chassis.
- All carriers or 1260-Series modules that do not have an Option-01T do have the Local Bus Jumper Assembly (P/N 405951) and Bus Grant Jumper Assembly (P/N 405951-003) installed. See **VXI Local Bus Connections** in **Chapter 2: Getting Started** in the Option-01T Instruction Manual.
- All twelve Local Bus daisy-chain switches are closed on all carriers and 1260-Series modules except the last one on the right. The last module on the right must have all twelve Local-Bus daisy-chain switches open. Also, if only one switch module (1260-100/101 Carrier or 1260-Series module) is used, then the Local Bus daisy-chain switches must all be open.

If this does not correct the problem, then proceed to step 11.

11. Try to isolate the problem to a single 1260-100/101 Carrier or 1260-Series module by removing others from the chassis. Remember always to install the Option-01T in the module that is left-most in the group.